



Pump specifications

Parts in contact with the wine	AISI 316L
Trolley and other pieces	AISI 304
Impeller	Neoprene
Connections	Mâcon 50
Maximum flow	400 hl/h
Maximum pressure	6 bar
Maximum temperature	80°C

Electric specifications

Power supply	400 V/AC 50/60hz
Engine power	3 kW
Maximum electric power	16A
Connections	Prise Hypra 3P+T 16A (others one request)
Cable's length	10 m
Electric panel	IP64

20170816 FTWINIlobesENG

To pump with wine's respect

Long distance remote control & serial speed variation

- ✓ Slow rotation speed
- ✓ Energy economic
- ✓ Quiet
- ✓ Turn off circuit when stopped
- ✓ Ergonomic
- ✓ Volumetric

24 months warranty



2 rue du petit cotât
89800 MALIGNY
Tél : + 33 (0)3 86 33 46 53



@mail : contact@planeteconcept.com



Wide operating range

- Mini 40 hl/h
- 150 hl/h diam 40 mm
- 250 hl/h diam 50 mm
- > 340 hl/h diam 70 mm

- ⊕ Flexibility of the freewheel mode at priming of natural filling circuit of pipes



Silent driving by notched belt

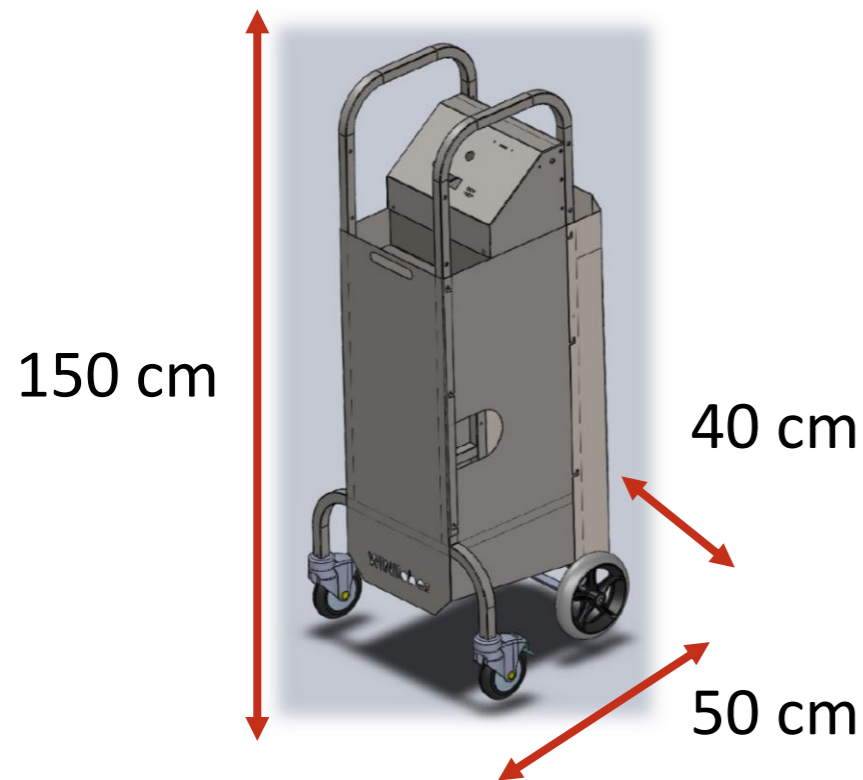

The compactest lobes' pump of the market



Autonomy:

- Pressures monitoring (Automatic stop on closed valve at aspiration and suppression)



- Tactil screen
Bulks programming & control



Program your transfers



Control your flow

Control your rate of flow

